

METOXIT dental
high tech ceramics

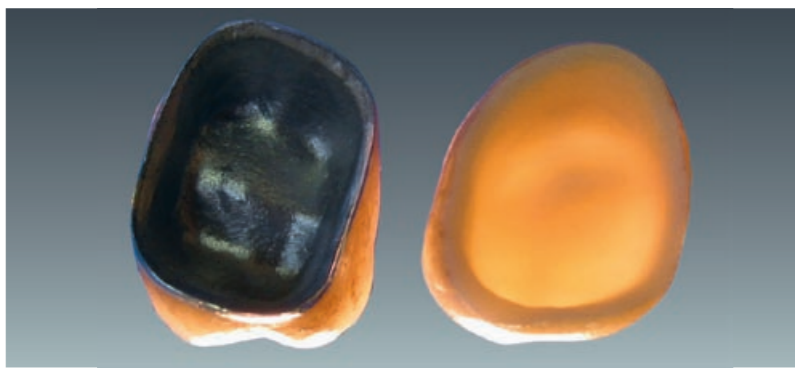

*The Swiss spirit
of innovation*



Material comparison: The image on the left shows a metal-ceramic crown and on the right a full ceramic crown made from homogeneously colored Z-CAD® zirconia. The translucency of Z-CAD® frameworks is by far closer to that of natural teeth.

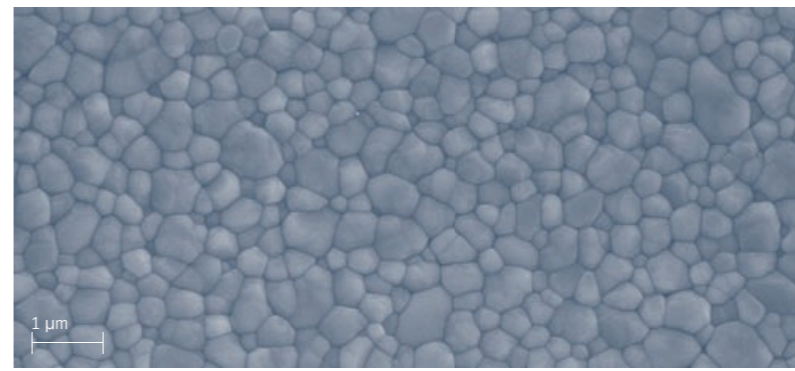

Electron micrograph of a sintered Z-CAD® blank, made from Y-TZP (yttria-stabilized tetragonal zirconia polycrystals): Metoxit AG materials are homogeneous and fulfil the highest requirements of ISO 13356 (implants for surgery – ceramic materials based on yttria-stabilized tetragonal zirconia (Y-TZP)).

Only the best is good enough

Healthful teeth contribute significantly to our quality of life. They are so conspicuous and an essential part of our appearance.

Dental technicians and dentists help their patients regain self-confidence thanks to beautiful, functional teeth. The right choice of materials is essential in this gratifying process.

Strong and beautiful

When teeth are manufactured from artificial biomaterials, it is essential to use ceramics of uncompromising quality in terms of appearance, mechanical strength and functional safety. Oxide ceramics such as Z-CAD® zirconia provide proofed effectiveness in this field. Moreover they are providing aesthetic and functional

Z-CAD® zirconia is

- biocompatible
- aesthetical
- high-strength
- proofed
- ...

advantages as well as excellent biocompatibility in comparison to other materials.

Ceramics are not all equal

Metoxit AG has many decades of experience in manufacturing medical products made of high-strength oxide ceramics like zirconia and alumina. Back in the 1980's, Y-TZP (yttria-sta-

bilized tetragonal zirconia polycrystals) and Y-TZP-HIP (HIP – Hot Isostatic Post Compaction) had already been proposed for use in dentistry as a result of positive experience with orthopedic hip implants made from Metoxit Y-TZP-HIP. From about 1990 onwards Metoxit Y-TZP-HIP has been used for root posts and interest grew to use this material additional-

ly in restorative dentistry applying the CAD/CAM technique. Since these very beginnings further important progress has been made in material composition and processing, making zirconia an excellent alternative to previously used materials.



“Since 1999 we are working successfully without metals in our dental laboratory. We concentrate solely on highly aesthetic restorations using ceramics only. Zirconia of Metoxit AG was an important component in the development of this new concept. Several thousand teeth made on our premises are based on this innovative high-tech ceramic made in Switzerland. Zirconia from Metoxit makes me feel safe. I feel comfortable, even after ten years.”

Joachim Maier, MDT, Oral Design Bodensee (Germany)

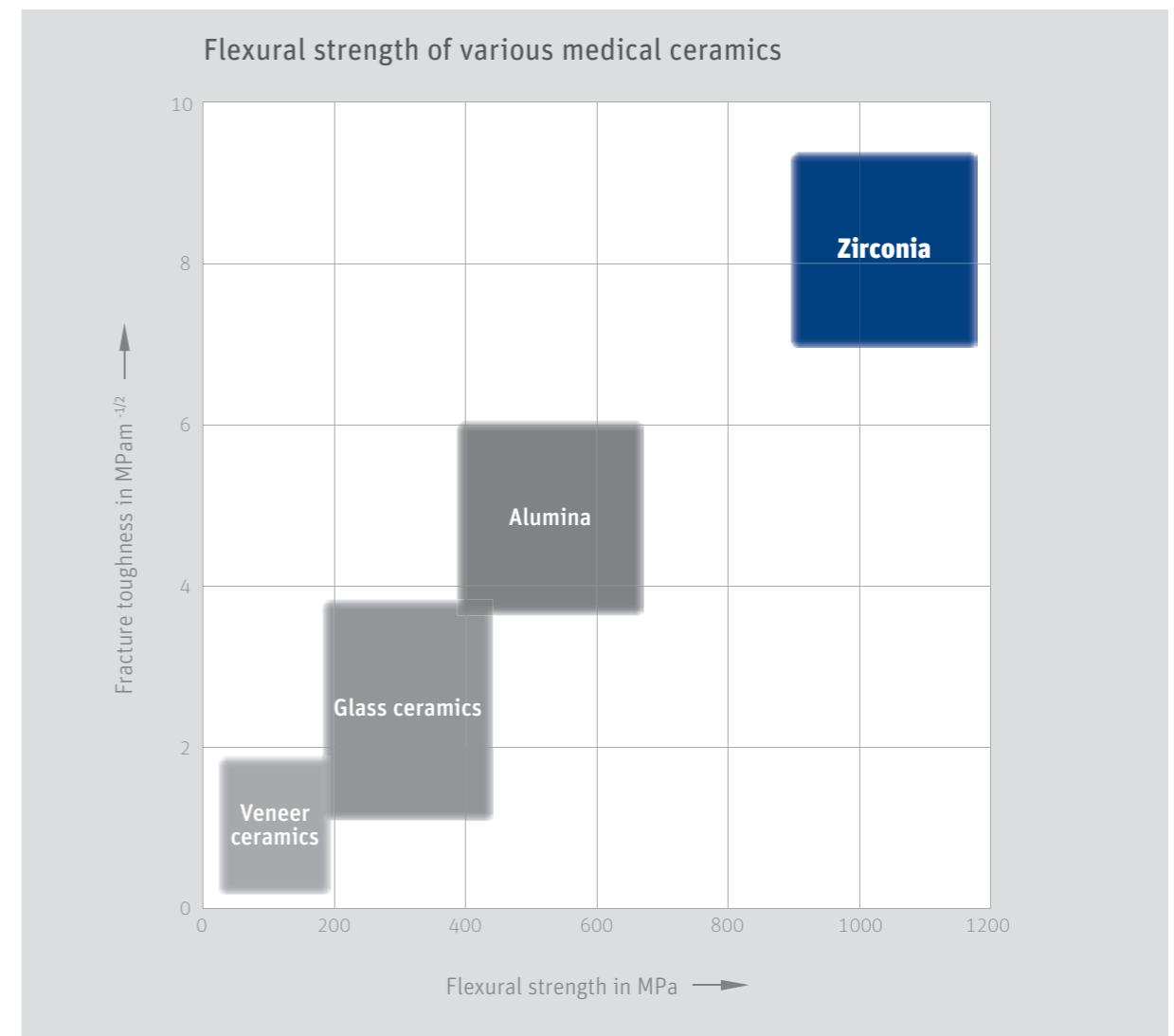



It's all in the Z-CAD® color

White is not just white

The appearance of a tooth is determined by the combination of its color intensity, translucency, opalescence, fluorescence and light reflection of its surface structure.

In the cervical and occlusal area dental technicians require a high de-

gree of color intensity but often have limited space available. This is where colored Z-CAD® zirconia has an advantageous optical effect.

Why making things difficult when they can be so easy?

It is common practice to dip white zirconia into chemical solutions to

Colored Z-CAD® zirconia

- is economical
- is homogenously colored
- allows differentiated coloring in restoration applications
- fulfils all respective international standards

The brightness value of a coping made from white Z-CAD® zirconia is intensified by the reflective white of the structure material, which can be seen in particular in cervical and occlusal areas (right of picture). The use of Metoxit AG colored Z-CAD® blanks (left of picture) neutralizes this effect, making the desired color easier to achieve.

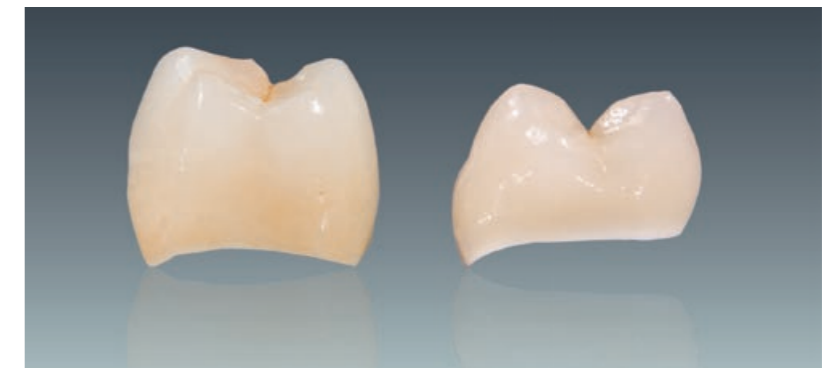

achieve the desired color. Only in the rarest cases this process is absolutely uniform and reproducible. The gradient in color intensity from crown to connector to pontic as a result of both, varying thicknesses and manual grinding after sintering is the reason for an uneven coloration.

In contrast, Metoxit AG applies a specific coloration process to the colored Z-CAD® zirconia powder creating an absolutely homogenous color. In addition, the time consuming drying process after dipping is no longer needed, saving dental technicians a considerable amount of time and money.

Furthermore, the Z-CAD® coloring process does not change mechanical characteristics and biocompatibility. Colored Z-CAD® zirconia meets all requirements of the respective international standards.

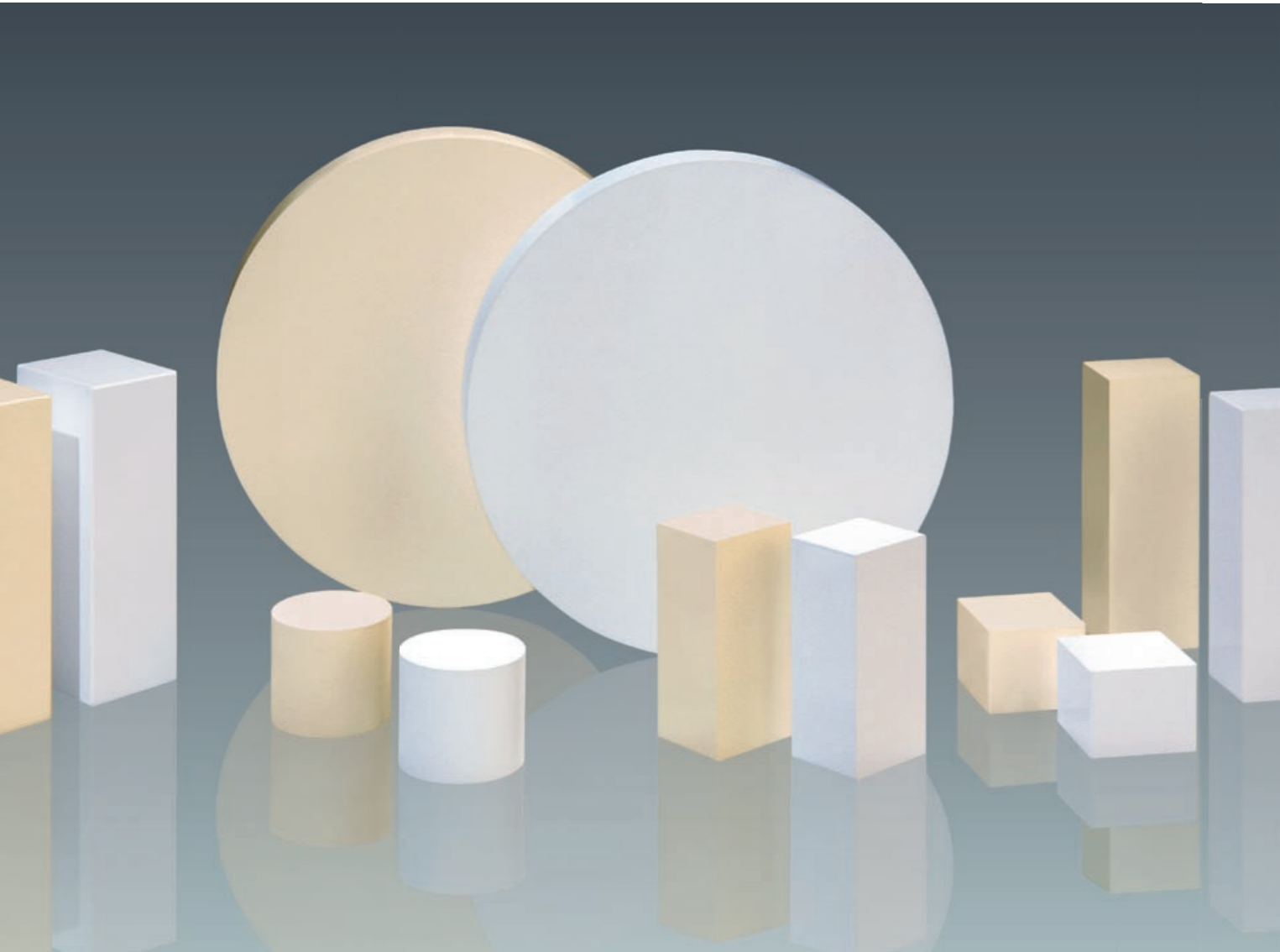

“ I need the best material whose quality is guaranteed in order to give my patients a biocompatible, gleaming smile — long-term. ”

Rainer Semsch, MDT,
Dental Concept, Münstertal (Germany)



The Swiss spirit of know-how

Metoxit – the bioceramics experts

More than twenty years ago, Metoxit AG was already one of the pioneers in the research and manufacturing of bioceramics. Over the years, Metoxit AG has expanded its know-how and now covers all steps of the production process from the raw powder to the final product. Whether axial or isostatic pressing – Metoxit always selects the pro-

duction process which achieves the best final product.

The R&D department is consistently improving materials and processes in order to carry on Metoxit AG's pioneering role in the bioceramics field. All test procedures conform to the latest technological advances and are amongst the toughest in the industry.

Metoxit AG

- has several decades of experience in the manufacture and processing of zirconia
- covers all processes from raw powder to the final product
- produces Z-CAD®
- has its own R&D and material testing laboratory

From the powder to the CAD/CAM framework

Valuable material produced under pressure

There are various ways to manufacture ceramic blanks. The isostatic and the uniaxial pressing processes are probably the ones most widely used in the production of dental CAD/CAM blanks. Metoxit AG has available the complete range of techniques for producing bioceramics. Fully automated production, reproducible processes and total traceability guarantee the highest quality possible.

Simply Pressure is not enough

Every CAM, CAD/CAM or copy milling system currently on the market requires ceramic blanks with certain specifications. In the production of blanks, attention must be paid to system parameters such as nature of cutter, milling or grinding parameters, but also the torque and feed rate of each system. Metoxit AG's Z-CAD® ceramic blanks are the product of over fifteen years' experience and are perfectly adapted to the demands of dental grinding and milling systems.

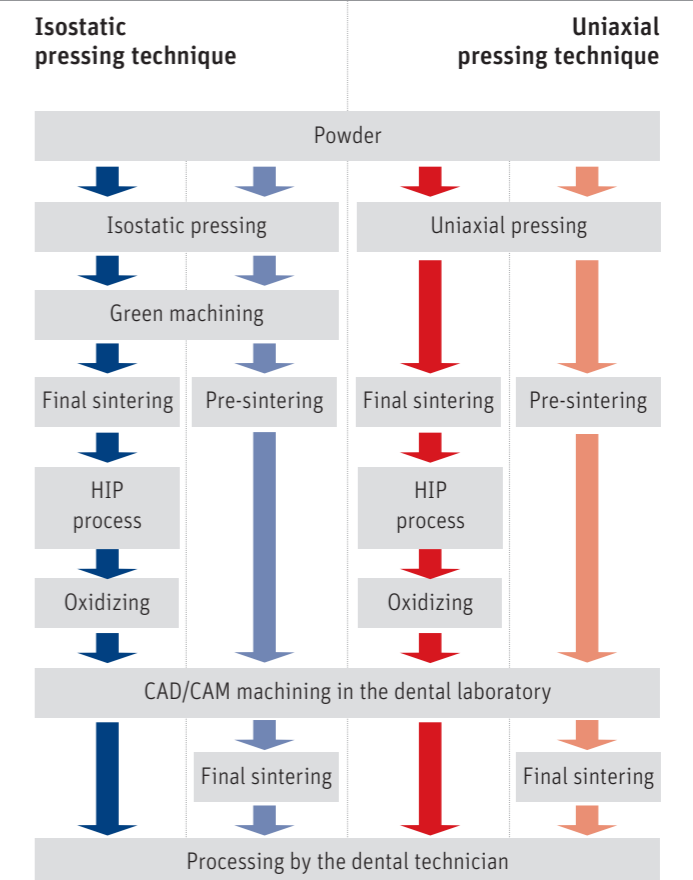

The flowchart shows the four common procedures: A distinction is made between the isostatic pressing technique during which pressure is uniformly applied to the powder, and the uniaxial pressing technique in which the product is compacted via mechanical pressure from above and below. If required both techniques can be combined with the HIP process (Hot Isostatic Post Compaction) in order to achieve the highest possible structural quality.

You can find more detailed information on the differences between the different techniques on the final pages under FAQs.



Z-CAD® blocks



Order No.	Product	Color	Measurements (L x W x H)	Packing unit
405643	Z-CAD 20-15 (10)	white	20 x 14 x 15 mm	10 pcs
405826	Z-CAD 20-15 (35)	white	20 x 14 x 15 mm	35 pcs
405827	Z-CAD 20-15 B2 (10)	B2	20 x 14 x 15 mm	10 pcs
405828	Z-CAD 20-15 B2 (35)	B2	20 x 14 x 15 mm	35 pcs
405829	Z-CAD 20-15 TL (10)	translucent	20 x 14 x 15 mm	10 pcs
405830	Z-CAD 20-15 TL (35)	translucent	20 x 14 x 15 mm	35 pcs



Order No.	Product	Color	Measurements (L x W x H)	Packing unit
405667	Z-CAD 20-19 (10)	white	20 x 19 x 15.5 mm	10 pcs
405831	Z-CAD 20-19 B2 (10)	B2	20 x 19 x 15.5 mm	10 pcs
405832	Z-CAD 20-19 TL (10)	translucent	20 x 19 x 15.5 mm	10 pcs

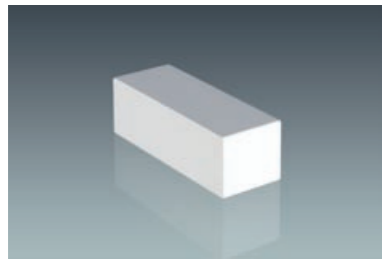

Order No.	Product	Color	Measurements (L x W x H)	Packing unit
405644	Z-CAD 40-15 (5)	white	40 x 14 x 15 mm	5 pcs
405833	Z-CAD 40-15 B2 (5)	B2	40 x 14 x 15 mm	5 pcs
405834	Z-CAD 40-15 TL (5)	translucent	40 x 14 x 15 mm	5 pcs



Order No.	Product	Color	Measurements (L x W x H)	Packing unit
405645	Z-CAD 40-19 (5)	white	39 x 19 x 15.5 mm	5 pcs
405835	Z-CAD 40-19 B2 (5)	B2	39 x 19 x 15.5 mm	5 pcs
405836	Z-CAD 40-19 TL (5)	translucent	39 x 19 x 15.5 mm	5 pcs

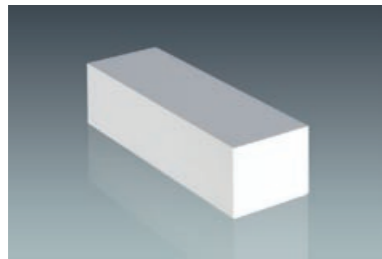

Order No.	Product	Color	Measurements (L x W x H)	Packing unit
405646	Z-CAD 55-19 (1)	white	55 x 19 x 15.5 mm	1 pc
405837	Z-CAD 55-19 B2 (1)	B2	55 x 19 x 15.5 mm	1 pc

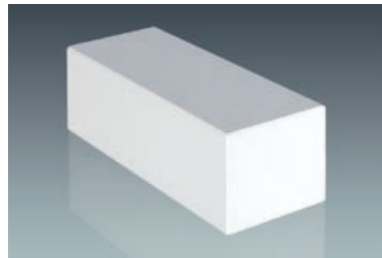

Order No.	Product	Color	Measurements (L x W x H)	Packing unit
405838	Z-CAD 65-25 (1)	white	65 x 25 x 22 mm	1 pc
405839	Z-CAD 65-25 B2 (1)	B2	65 x 25 x 22 mm	1 pc

Z-CAD® discs



Z-CAD® discs standard				
Order No.	Product	Color	Measurements	Packing unit
405454	Z-CAD HD99-10 (1)	white	∅ 99 ± 0.6 x 10 mm	1 pc
404953	Z-CAD HD99-14 (1)	white	∅ 99 ± 0.6 x 14 mm	1 pc
404954	Z-CAD HD99-18 (1)	white	∅ 99 ± 0.6 x 18 mm	1 pc
405008	Z-CAD HD99-20 (1)	white	∅ 99 ± 0.6 x 20 mm	1 pc
404955	Z-CAD HD99-25 (1)	white	∅ 99 ± 0.6 x 25 mm	1 pc
405455	Z-CAD HD99-10 B2 (1)	B2	∅ 99 ± 0.6 x 10 mm	1 pc
404956	Z-CAD HD99-14 B2 (1)	B2	∅ 99 ± 0.6 x 14 mm	1 pc
404957	Z-CAD HD99-18 B2 (1)	B2	∅ 99 ± 0.6 x 18 mm	1 pc
405010	Z-CAD HD99-20 B2 (1)	B2	∅ 99 ± 0.6 x 20 mm	1 pc
404959	Z-CAD HD99-25 B2 (1)	B2	∅ 99 ± 0.6 x 25 mm	1 pc



Z-CAD® discs with 10 mm collar				
Order No.	Product	Color	Measurements	Packing unit
405415	Z-CAD HD99-10 C10 (1)	white	∅ 98.5 ± 0.5 x 10 mm	1 pc
405364	Z-CAD HD99-14 C10 (1)	white	∅ 98.5 ± 0.5 x 14 mm	1 pc
405366	Z-CAD HD99-18 C10 (1)	white	∅ 98.5 ± 0.5 x 18 mm	1 pc
405416	Z-CAD HD99-20 C10 (1)	white	∅ 98.5 ± 0.5 x 20 mm	1 pc
405417	Z-CAD HD99-25 C10 (1)	white	∅ 98.5 ± 0.5 x 25 mm	1 pc
405418	Z-CAD HD99-10 C10 B2 (1)	B2	∅ 98.5 ± 0.5 x 10 mm	1 pc
405419	Z-CAD HD99-14 C10 B2 (1)	B2	∅ 98.5 ± 0.5 x 14 mm	1 pc
405420	Z-CAD HD99-18 C10 B2 (1)	B2	∅ 98.5 ± 0.5 x 18 mm	1 pc
405421	Z-CAD HD99-20 C10 B2 (1)	B2	∅ 98.5 ± 0.5 x 20 mm	1 pc
405422	Z-CAD HD99-25 C10 B2 (1)	B2	∅ 98.5 ± 0.5 x 25 mm	1 pc



Z-CAD® discs with plastic ring, inner (outer) diameter 93.5 mm (98.5 mm)				
Order No.	Product	Color	Measurements	Packing unit
405750	Z-CAD HD99-10 C10P (1)	white	∅ 98.5 ± 0.5 x 10 mm	1 pc
405757	Z-CAD HD99-14 C10P (1)	white	∅ 98.5 ± 0.5 x 14 mm	1 pc
405758	Z-CAD HD99-18 C10P (1)	white	∅ 98.5 ± 0.5 x 18 mm	1 pc
405761	Z-CAD HD99-10 B2 C10P (1)	B2	∅ 98.5 ± 0.5 x 10 mm	1 pc
405762	Z-CAD HD99-14 B2 C10P (1)	B2	∅ 98.5 ± 0.5 x 14 mm	1 pc
405763	Z-CAD HD99-18 B2 C10P (1)	B2	∅ 98.5 ± 0.5 x 18 mm	1 pc

Translucent versions of all discs available on request.

Z-CAD® cylinders/blocks | BIO HIP® blanks



Order No.	Product	Color	Measurements	Packing unit
405378	Z-CAD D16-16 (10)	white	Ø 16 x 16 mm	10 pcs
405589	Z-CAD D16-16 B2 (10)	B2	Ø 16 x 16 mm	10 pcs

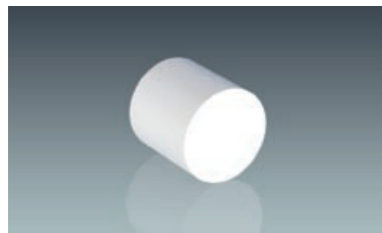

Order No.	Product	Color	Measurements	Packing unit
405586	Z-CAD D20-20 (10)	white	Ø 20 x 20 mm	10 pcs
405590	Z-CAD D20-20 B2 (10)	B2	Ø 20 x 20 mm	10 pcs



Order No.	Product	Color	Measurements (L x W x H)	Packing unit
405592	Z-CAD 42-16 (8)	white	43 x 20 x 16 mm	8 pcs
405594	Z-CAD 42-16 B2 (8)	B2	43 x 20 x 16 mm	8 pcs



Order No.	Product	Color	Measurements (L x W x H)	Packing unit
405624	Z-CAD 42-20 (8)	white	43 x 20 x 20 mm	8 pcs
405597	Z-CAD 42-20 B2 (8)	B2	43 x 20 x 20 mm	8 pcs

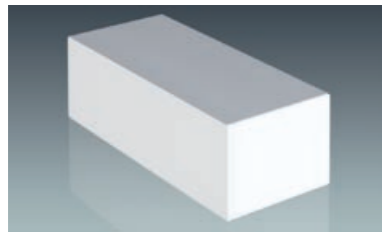

Order No.	Product	Color	Measurements (L x W x H)	Packing unit
405598	Z-CAD 60-25 (4)	white	60 x 20 x 25 mm	4 pcs
405599	Z-CAD 60-25 B2 (4)	B2	60 x 20 x 25 mm	4 pcs

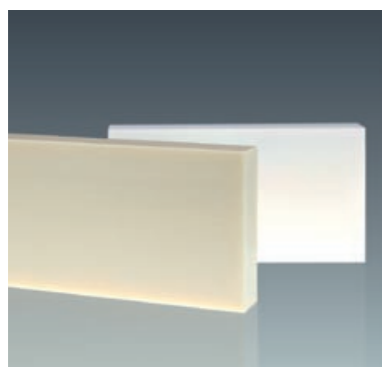

Z-CAD® BIO HIP® blanks (without metal bar)				
Order No.	Product	Color	Measurements	Packing unit
404657	Z-CAD HIP 80-8 (1)	white	79.5 x 42.5 x 8 mm	1 pc
404658	Z-CAD HIP 80-10 (1)	white	79.5 x 42.5 x 10 mm	1 pc
404659	Z-CAD HIP 80-12 (1)	white	79.5 x 42.5 x 12 mm	1 pc
404660	Z-CAD HIP 80-14 (1)	white	79.5 x 42.5 x 13.5 mm	1 pc
404661	Z-CAD HIP 80-15 (1)	white	79.5 x 42.5 x 15 mm	1 pc
404663	Z-CAD HIP 80-8 B2 (1)	B2	79.5 x 42.5 x 8 mm	1 pc
404665	Z-CAD HIP 80-10 B2 (1)	B2	79.5 x 42.5 x 10 mm	1 pc
404666	Z-CAD HIP 80-12 B2 (1)	B2	79.5 x 42.5 x 12 mm	1 pc
404667	Z-CAD HIP 80-14 B2 (1)	B2	79.5 x 42.5 x 13.5 mm	1 pc
404668	Z-CAD HIP 80-15 B2 (1)	B2	79.5 x 42.5 x 15 mm	1 pc

Tested to the limits

What other people say about Metoxit quality

Metoxit Z-CAD® products are tested and certified worldwide. Metoxit AG's Z-CAD® zirconia fulfils the strict requirements set by examiners in the USA, Canada, Japan, and Europe.





Literature

You will find below a list of important and interesting publications on the subject of bioceramics in English and German. Some of these articles can be found on our homepage www.metoxit.com in the download area. Please contact us if you are interested in a specific article.

- M. Andriottell
Survival rate and fracture resistance of Zirconium dioxide implants after exposure to the artificial mouth: An in vitro study.
 In: Inaugural Dissertation, Medizin. Fakultät, Univ. Freiburg i. Br., 2006.
- P. W. Fässler
Untersuchungen zur Bruch- und Dauerfestigkeit der Dentalkeramiken Zirkonoxid-TZP und Inceram.
 In: Inaugural-Dissertation der Medizinischen Fakultät. Universität Tübingen, 1999.
- T. Fett, W. Hartlieb, K. Keller, B. Knecht, D. Munz, W. Rieger
Subcritical crack growth in high-grade alumina.
 In: Journal of Nuclear Materials 184 (1991): 39-46.
- H. Fischer, D. Edelhoft, R. Marx
Mechanische Beanspruchbarkeit von Zirkonoxid-Wurzelstiften.
 In: Dtsch. Zahnärztl. Z. 53 (1998) 12: 854-858.
- J. Geis-Gerstorfer, P. Fässler
Untersuchungen zum Ermüdungsverhalten der Dentalkeramiken Zirkonoxid-TZP und Inceram.
 In: Dtsch. Zahnärztl. Z. 54 (1999) 11, 692-694.
- J. Geis-Gerstorfer, P. Fässler, R. Kirmeier
Fatigue behaviour of three all-ceramic materials.
 IADR 2002, San Diego, seq. 348: In: Ceramic properties and compositions.
- G. Graber, C. Besimo
Das DCS-Hochleistungs-System.
 In: Quintessenz Zahntechnik.: 57-64.
- E. A. Hegenbarth
Die Entwicklung keramischer Abutments.
 In: Implantologie, 2001, 329-335.
- W. Hotz, U. Volz
Erste Erfahrungen mit ZrO₂-Implantaten der neuesten Generation.
 Implantologie-Journal 8/2004.
- L. M. Junge
Klinische Erfahrungen mit 2 vollkeramischen Wurzelstift-Systemen.
 In: Dissertation, RWTH Aachen, 2002.
- Y. Kakehashi, H. Lüthy, R. Naef, A. Wohlwend, P. Schärer
A New All-Ceramic Post and Core-System: Clinical, Technical and In Vitro Results.
 In: The International Journal of Periodontics and Restorative Dentistry, Vol. 18, 6 (1998): 587-592.
- S. Köbel
Mechanische Eigenschaften von TZP BIO HIP.
 In: Technical Report, Metoxit AG, 19.10.2006.
- R. J. Kohal, D. Weng, M. Bächli, G. Klaus
Zirkonoxid-Implantate unter Belastung.
 In: Z. Zahnärztl. Impl. 2003, 19, 2.88-9 36
- R. J. Kohal, G. Klaus
A Zirconia-Implant-Crown System. A Case Report.
 In: The Intern. Journal of Periodontics and Restorative Dentistry, Vol. 24, No. 2, 2004: 147-153.
- R. J. Kohal, G. Klaus
Zirconia Implant Supported All Ceramic Crowns Withstand Longterm Load.
 In: Clin. Oral Impl. Res. 17, 2006: 565-572.
- R. Luthardt, W. Rieger, R. Musil
Grinding of Zirconia TZP in Dentistry.
 In: L. Sedel, C. Rey. Bioceramics 10, 1997. Proc. of the 10th Int. Symposium on Ceramics in Medicine. Oct. 5-8, 1997: 437-440.
- R. Luthardt, Holzhüter, Sandkuhl, Herold, Walter
Festigkeit und Rand zonenschädigung von Zirconia-TZP-Keramik.
 In: Dtsch. Zahnärztl. Z. 55 (2000) 11
- G. Natt, R. Marx, H. Spiekermann, J. Tinschert
Metallfreie Frontzahn-Brücken aus Hochleistungs-Keramik.
 In: Dental-Labor XLVII, Heft 6/1999, 999-1000.

W. Rieger
Gehäuse für Armbanduhren aus ZrO₂.
 In: Industrie Diamanten-Rundschau IDR 22 (1988) 3: 2-4.

W. Rieger
Bearbeitung von Al₂O₃-Keramik mit Diamant-Schleifscheiben.
 In: IDR 22 (1988) 4: 2-6.

W. Rieger
Medical Applications of Ceramics.
 In: High Tech Ceramics: Viewpoints and Perspectives. G. Kostorz (Hrsg). Academic Press, 1989: 191-228.

W. Rieger
Wirtschaftliche Bearbeitung technischer Keramik.
 In: Sprechsaal 122, No. 1, 1989.

W. Rieger
Konstruieren mit Keramik: ein Problem?
 In: Chimia 43 (1989): 309-314.

W. Rieger
Aluminium- und Zirkonoxidkeramik in der Medizin.
 In: Industrie Diamanten Rundschau, IDR 2/1993: 2-6.

W. Rieger
Studies of Biocompatibility of ZrO₂ and Al₂O₃ Ceramics.
 6th Biomaterials Symposium, Sept. 1994, Göttingen.

W. Rieger, M. Schweiger
Bearbeitung von Zahnstiften für die Zahnmedizin.
 In: IDR 31 (1997), Nr. 4: 328-330.

W. Rieger
Experience on Zirconia Ceramic Femoral Heads.
 Proc., Zirconia Symposium, 6th World Biomaterials Congress, Hawaii, 2000.

W. Rieger
Ceramics in Orthopedics – 30 Years of Evolution and Experience.
 In: World Tribology Forum in Arthroplasty. C. Rieker, S. Oberholzer, (Hrsg.). Bern: Hans Huber, 2001: 283-294.

W. Rieger
Zirkonoxid als Spitzenwerkstoff für die Dentaltechnik.
 Firmeninfo, Metoxit AG, 2001.

W. Rieger, W. Weber, M. Schmidt
Dentalimplantate aus ZrO₂-Keramik Kolloquium.
 In: EMPA. Dübendorf, CH, Nov. 2004.

J. Tinschert, G. Natt, B. Doose, H. Fischer, R. Marx
Seitenzahnbrücken aus hochfester Strukturkeramik.
 In: Dtsch. Zahnärztl. Z. 54 (1999) 9: 545-550.

J. Tinschert, G. Natt, A. Jorewitz, H. Fischer, H. Spiekermann, R. Marx
Belastbarkeit vollkeramischer Seitenzahnbrücken aus neuen Hartkern-Keramiken.
 In: Dtsch. Zahnärztl. Z. 55 (2000) 9: 610-616.

J. Tinschert, D. Zwez, R. Marx, K. Anusavice
Structural Reliability of alumina, feldspar, leucite, mica and zirconia based ceramics.
 In: J. of Dentistry 28 (2000): 529-535.

J. Tinschert, G. Natt, P. Latzke, K. Schulze, N. Heusser, H. Spiekermann
Vollkeramische Brücken aus DC-Zirkon: Ein neues klinisches Konzept mit Erfolg?
 In: Dtsch. Zahnärztl. Z. 60 (2005) 8: 435-445.

J. Tinschert, G. Natt, N. Mohrbotter, H. Spiekermann
Lifetime of Alumina and Zirconia Ceramics Used for Crown and Bridge Retaurations.
 In: J. of Biomedical Research Materials Part B: Applied Biomaterials 2006, in print.

W. Weber, W. Rieger
ZrO₂-TZP in Dentistry: Materials, Properties and Applications. Proc. of the 13th Int. Symposium on Ceramics in Medicine.
 Bologna, Italy. 22-26. Nov. 2000. In: Key Engineering Materials 192-195 (2001): 929-932.

W. Weber, W. Rieger, J. Clausen, H. Schmotzer
Zirconia-Alumina: An Alternative Bearing for Hip Arthroplasty. Proc. of the 13th Int. Symposium on Ceramics in Medicine.
 Bologna, Italy, Nov. 22-26, 2000. In: Key Engineering Materials 192-195 (2001): 533-536.

S. Witkowski
High Tech Biokeramiken für die Zukunft.
 In: Quintessenz Zahntechnik 32, 1(2006). 66-76.

Datenblatt, Metoxit AG, 1994
 Biokeramische Hüftimplantate.

Datenblatt, Metoxit AG
 ATZ/ZIRALDENT® (2006).

FAQs

What is the difference between the uniaxial and the isostatic pressing techniques?

Isostatic pressing technique

Ceramic powder is filled into a malleable die that is placed in a pressure vessel. The applied pressure (2000–4000 bar) is distributed uniformly throughout the whole volume. Isostatic pressing technique results in highly homogenous blanks in respect

of density and shrinkage. Blanks processed by this technique allow the reliable preparation of large frameworks like wide span bridges.

Uniaxial pressing technique

The ceramic powder is compressed simultaneously by two pistons moving within a die in opposite direction. During pressing, powder is compressed higher close to the pistons—density in the center of the blanks is thus

slightly lower than at the edges. Hence shrinkage variations during sintering result.

Uniaxial pressing is the preferred technique for the production of small rectangular blocks where these variations are negligible. This process is economically attractive. However, blanks should be used for frameworks with a maximum of four units only.

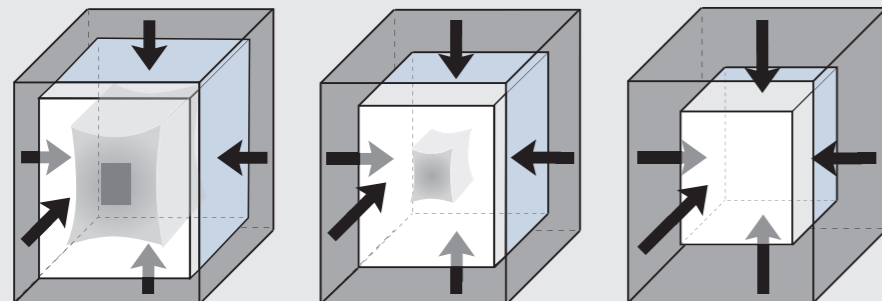

Isostatic pressing

Advantage
Homogenous density distribution in the porous body

Disadvantage
Greater production expense

Structure construction in all sizes possible

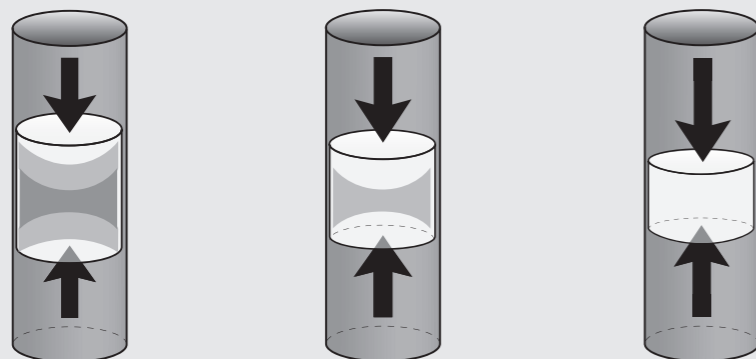

Uniaxial pressing

Advantage
Very economical production

Disadvantage
Less uniform density distribution

Not recommended for large frameworks

What makes a good zirconia?

Strength and reliability of zirconia is determined by raw material quality and the craftsmanship in all processing steps. It is essential to avoid pores and flaws from the very beginning. Experience and a high degree of understanding of this material are therefore of utmost importance during its manufacture. This is what Metoxit AG stands for.

Is Z-CAD® zirconia radioactive?

Many ores contain traces of radioactive elements, so does the ore zirconia is extracted from. It is therefore important to use powders from which radioactive components have been meticulously filtered out during the production process. Metoxit AG's quality-ensured processes guarantee that this happens.



Can any sintering program be used for all the zirconia blanks available on the market?

No. There are different zirconia powders which require different sintering temperatures and process time. The size of the object to be sintered is also significant. The larger the object, the more important it is to adjust sintering parameters precisely.

Why do zirconia blanks have different enlargement factors for different CAD/CAM systems?

Dental CAD/CAM systems are largely different—so are the blanks that fit the systems. Each system therefore requires individually aligned blank parameters. Because of these specification differences, it is not advisable to use a blank on a system to which it has not been aligned.

Why are some porous zirconia blanks machined by grinding and others by milling?

Grinding is required for machining hard and brittle materials like fully sintered ceramics. Some of the most versatile machines on the mar-

ket grind a wide range of materials, including glass-ceramics.

Milling is more efficient for machining softer materials like plastics, metals and porous ceramic blanks. Some of the fastest machines on the market are optimized to mill just a few different materials at very high speed.

Not only the zirconia blank dimension but also its physical properties like density and hardness need to be aligned with the CAM hardware and its machining technique. Independent of hardware and technique, Metoxit AG aims to provide blanks that result in the best end-product.

How does chipping and fracture occur during milling and grinding processes?

Like CAD/CAM systems differ, so do the blanks that work best with them. The blank characteristics must therefore be aligned to the CAM module and the cutting tools applied.

Poor alignment can result in chipping and fractures during the manufacturing process. The work has to be repeated. The most common cause of flaws, however, is blunt tools.

Tip: Always use sharp tools when machining high-quality Z-CAD® blanks.

FAQs

Can milled or ground zirconia be recycled and made into new blanks?

No, the milling and grinding chips can not be processed into blanks again.

Why do flexural strength values differ in different publications about zirconia products?

Three different tests exist to determine the flexural strength of dental ceramics: the 3-point, the 4-point and the biaxial flexural strength test (see pictures below). These tests methods differ in sample size and geometry. Minimum requirements and test procedures for flexural strength tests of

this kind are described and defined by international standards. In order compare flexural strength data, test methods must be identical.

Is it necessary to give the structure the basic dentin color?

White zirconia is a good light reflector. This can increase the brightness value in areas where a lot of chroma is required, particularly in the cervical and occlusal areas. In these areas, veneer ceramics are the thinnest. It is unnecessary to stain the structure with the corresponding dentin color, but a tone must be selected which neither increases the brightness value nor is too intense. It has been shown that

Metoxit Z-CAD® blanks meet this requirement very well. Colored Z-CAD® blanks prove to be more cost-effective than coloring porous frameworks by dipping; there is no lengthy drying process and the color of sub-structures from colored Z-CAD® blanks is always reproducible.

What is a green body?

In order to produce a dimensionally stable blank from a powdery material by pressing, the addition of binder fractions is required. This blank is referred to as a "green body", however it does not yet exhibit its system-specific properties and the final geometry.

During the individual pre-sintering process, which is different for every CAD/CAM system, these binder fractions are burned off and the structure is partially sintered. Thereafter, the blank has the defined properties for its use in the intended CAD/CAM system. This blank is then referred to as a "white body" and corresponds to the product used by the dental technician in the lab. In order to prevent confusion, it is recommended to refer to these blanks as partially sintered, or pre-sintered.

What are the differences between "translucent" and "opaque" zirconia?

The common abbreviation for zirconia which has been stabilized with yttria is Y-TZP, which stands for "yttria-stabilized zirconia polycrystals". At the end of the 1990's it was found that alloying Y-TZP with a small proportion of alumina improves durability, in particular at high temperatures in humid environments. The name of this material is abbreviated to TZP-A

and today it is the most widely used zirconia for dental restorations.

The only disadvantage of this small proportion of alumina is a slight reduction in the translucence of the zirconia. Therefore zirconias marketed as "translucent" are most likely made from Y-TZP and "opaque" blanks from TZP-A.

Metoxit AG is working constantly on the advancement of their products and broadening of the product range.

The 3-point, the 4-point and the biaxial flexural strength test (from left to right)

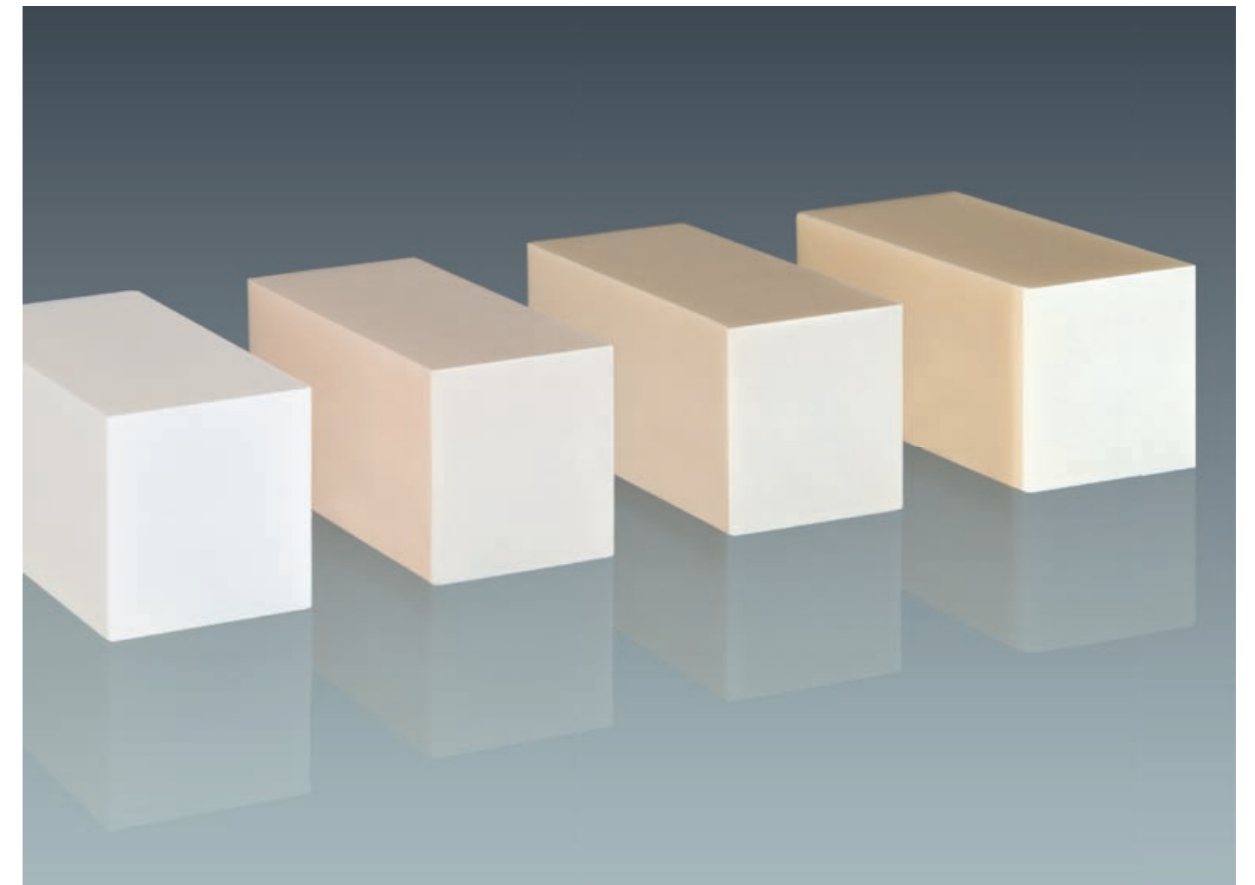
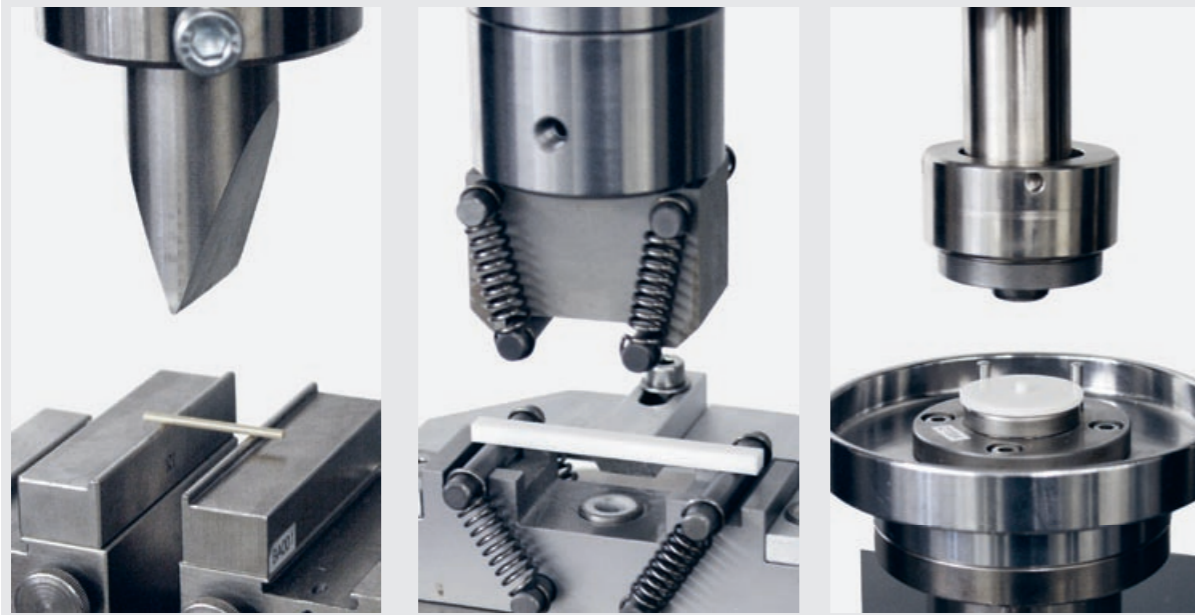

Why Metoxit?

Today, a variety of companies supply dental zirconium oxide blanks. How does Metoxit AG differ from other manufacturers?

Pioneer

Metoxit AG is one of the pioneers in the manufacture of dental zirconium oxide products. The company has more than 20 years of experience in the

production of medical products made from oxide ceramics and more than 15 years of experience in the field of dental ceramics.

The first clinical study relating to the use of zirconium oxide in the posterior tooth area published in Germany in 1999 was conducted with the CAD/CAM blanks from Metoxit AG.

Trusted by millions

Since 1993, Metoxit AG has produced CAD/CAM blanks for more than ten million prosthetic units!

Repeatable quality

Metoxit AG employs a fully automatic production operation for the economical and repeatable manufacture of medical products.

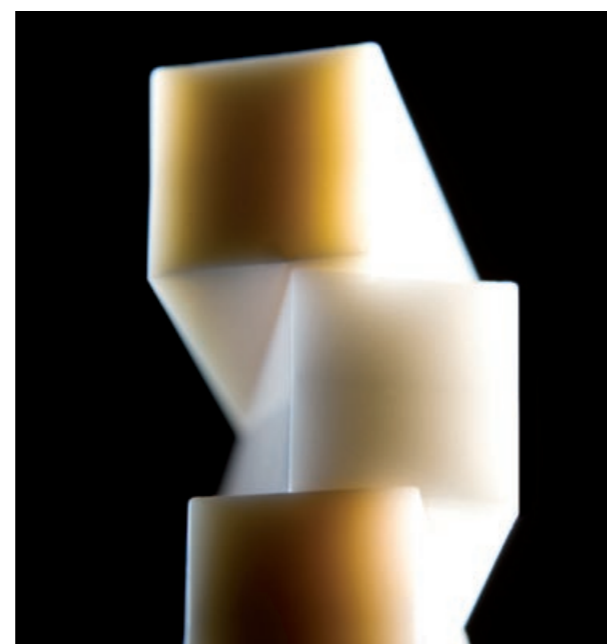

Trusted by millions*

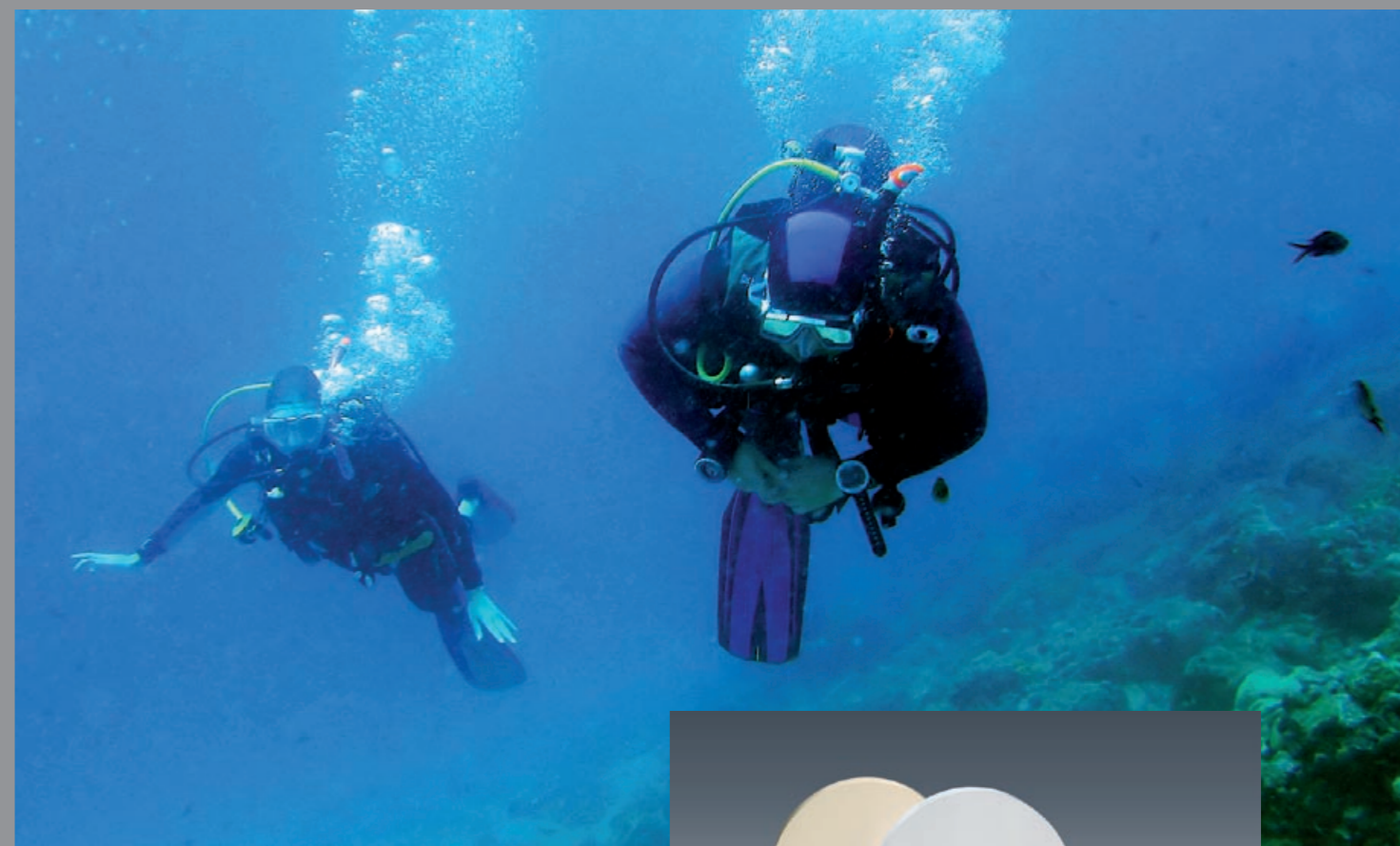

In areas where maximum quality is needed, people rely on proven and first-rate equipment. After all, who would ever think of trusting mediocre equipment while diving?

To the highest degree, the quality and innovation standard applies to products we must integrate in our body — such as ceramics for dental prosthetic restorations.

For further information, please ask your CAD/CAM system manufacturer for the zirconium oxide blanks from Metoxit AG trusted by millions.

* Since 1993, Metoxit AG has produced CAD/CAM blanks for more than 10 million prosthetic units.

METOXIT

high tech ceramics

Metoxit AG Emdwiesenstrasse 6 P.O. Box 160 CH-8240 Thayngen
phone +41 (0)52 645 01 01 fax +41 (0)52 645 01 00 e-mail info@metoxit.com www.metoxit.com